

# **Collamat® 8600**

## Operating instructions

## Index

Page

1	Safety advices .....	2
1.1	Important warnings .....	2
1.2	Danger indications .....	2
1.3	Symbol descriptions .....	3
2	General informations .....	4
2.1	Special characteristics of the Collamat® 8600: .....	4
2.2	The Labeler C8600 .....	4
3	Operating manual .....	5
3.1	Assembly parts .....	5
3.2	Threading the label web .....	6
3.3	Adjustment of rewinder coupling force .....	6
3.4	Readjustment of paper brake .....	7
3.5	Longitudinal adjustment on the module rail .....	7
3.6	Flap adapter .....	8
3.6.1	Inclination adjustment of flap adapter .....	8
3.6.2	Adjustment of the pressure roller of the flap adapter .....	8
3.7	Optical label scanner .....	9
3.8	Adjustment of the mechanical label scanner .....	10
4	Nonstop labeling .....	11
5	Servicing .....	12
6	Glossary .....	12
6.1	Short cuts .....	12
6.2	Signals .....	12
6.3	Terms .....	13
7	Technical data .....	14
8	Connection diagram .....	16
9	Trouble shooting checklist .....	17

# 1 Safety advices

## 1.1 Important warnings



Before installing and operating the Collamat® 8600 read following safety instructions:

- The Collamat® 8600 labeler is exclusively determined for labeling goods. It must exclusively be controlled and driven by a C8600 monitor.
- The installation of a Collamat® 8600 has to be done by a trained specialist. For this you have to consider the national specific regulations of
  - prevention of accidents
  - mechanical stability
  - construction of electrical and mechanical systems
  - noise suppression
- Take notice to the technical data of the Collamat® 8600. Especially the environment conditions must be observed.
- The operation of the Collamat® 8600 must be done by trained personnel.
- In case of non-authorized modification, guarantee will fall.
- Before connecting non-standard products, ask your competent technical supporter.

## 1.2 Danger indications

- The safety symbols and danger advices on the Collamat® 8600 and in this manual must strictly be observed.
- Before connecting or disconnecting the labeler to or from the monitor C8600 the monitor must be switched off.
- The monitor and the distribution box may only be opened by authorized personnel.
- Before opening the distribution box, the monitor must be separated from the mains power.
- It exists danger of pinching hair, jewelry, ties, clothes etc. into the traction unit.
- It exists danger of injury by cutting fingers in the area of the paper web.
- It exists danger of injury in the area of the dancers of the rewinder and unwinder of the Collamat® 8600.
- It exists danger of injury in the area of the paper stockcontroller of the Collamat® 8600.
- To operate on the Collamat® 8600 the operating personnel must keep to a safely place to prevent injury by the products being labeled.

## 1.3 Symbol descriptions



**ATTENTION**

Indicates danger of damaging the Collamat® 8600 or other system components, with a potential consequential danger of injuries.

**DANGER**

Indicates an immediate hazard for persons.

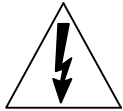

**DANGER**

Shock hazard due to high voltage at component.



**DANGER**

Hazard due to high temperature component.



**ATTENTION**

ESD warning (Electro Static Discharge). The PC boards or component may only be touched in an electrostatically protected environment.

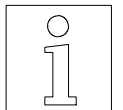

**NOTE**

Important or additional information to Collamat® 8600 or to the documentation.

## 2 General informations

### 2.1 Special characteristics of the Collamat® 8600:

- resistant to wear, no clutch/brake-system
- robust, stable
- easy installation and operation due to the modular construction
- simple to operate due to the menu operated software
- quick change-over to other labeling tasks
- high performance
- high reliability
- latest SMD-technology
- 20 program memories
- high precision 3-phase stepper motor

The modular system allows the addition of the peripheral appliances on a module rail. The complete electronic operating and electronic control system for the traction unit are installed into a modern, elegant box. The connection to the particular peripheral units takes place through the traction unit on the module rail. An essential advantage is the expansion of the system without extra expenditure in the basic system itself. A microprocessor controlled system, a multiple line LCD and a neatly arranged keyboard grant a comfortable operating of the Collamat® 8600. All surfaces of the units are treated against water and they are corrosion resistant. The coating of the traction unit is specially treated to avoid slippage on the paperweb while labeling.

### 2.2 The Labeler C8600

The traction unit as well as the other peripheral units are mounted on a modular rail. The force of the paperbrake is adjustable. The traction roller turns free while power off for easy threading and installation of the paperweb.



**The installation of the Collamat® 8600 must be done by a trained personnel. For this you have to consider the national specific regulations of**

- **prevention of accidents**
- **noise suppression**
- **mechanical stability**
- **construction of electrical and mechanical systems**

## 3 Operating manual

### 3.1 Assembly parts

In the following description the assemblies of the Collamat® 8600, their adjustment and maintenance are described. First an overall view of the dispenser.

The assembly parts are mounted and placed on a modular rail. Following figure 1 shows these assembly parts with their names:

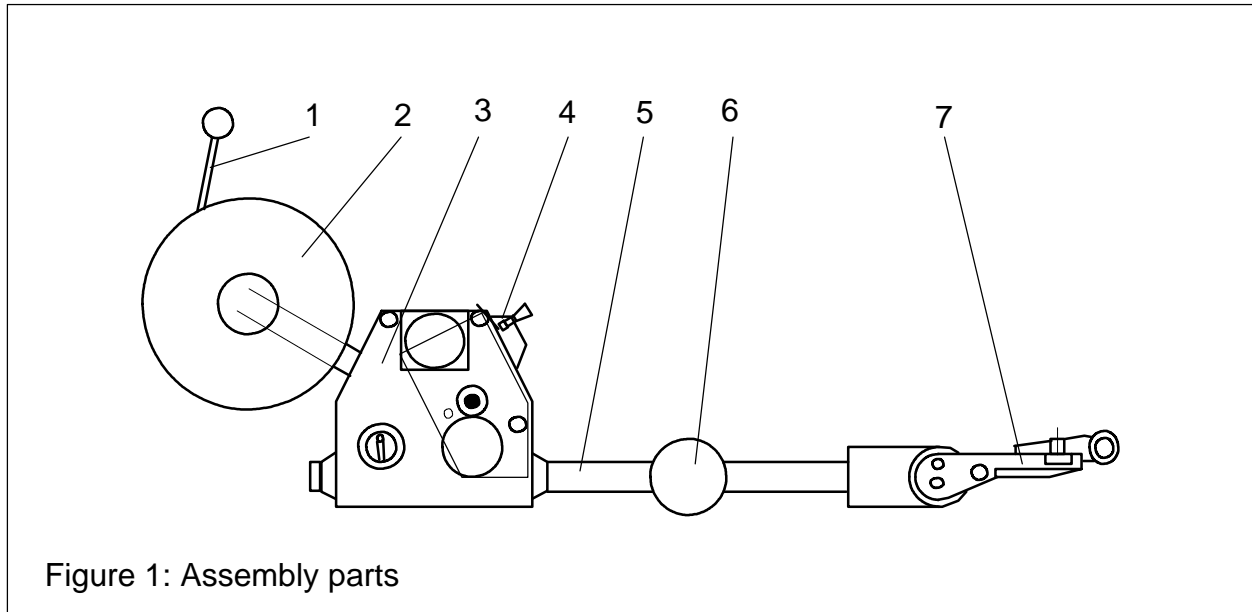

#### Legend of the assemblies

1. Unwinder dancer
2. Unwinder
3. Traction unit
4. Paper brake
5. Modular rail
6. Support
7. Adapter (optional with magnet)



**The traction unit may only be opened by trained personnel. It contains no user serviceable parts.**



**High voltage inside of the traction unit . Danger of shock hazard due to high voltage at the components.**

### 3.2 Threading the label web

Thread the label web as shown in figure 3 up to the dispensing edge and draw it out by approx. 1 m. Detach the labels from the paperweb at the drawn-out web. Then open the pinchroller by turning the knob **(1)**, place the paperweb over the dispensing edge and finish threading the paperweb as shown in figure 3. Close the pinchroller. Adjust the side guides of the paperweb well, leaving 0.5 mm free space to the paperweb's edge.

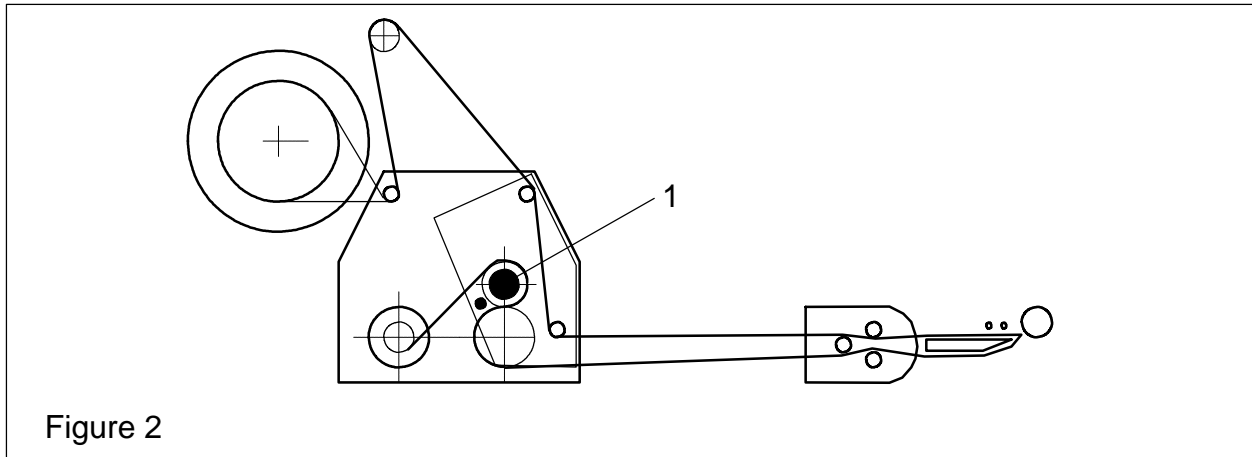

Figure 2

### 3.3 Adjustment of rewinder coupling force

The coupling force of the rewinder is factory-set. Proceed as follows if out of adjustment:

Detach winding spindle **(1)** after unscrewing the M5-bolt **(3)**. Screw M8-bolt **(2)** accordingly:

- in = harder coupling
- out = softer coupling

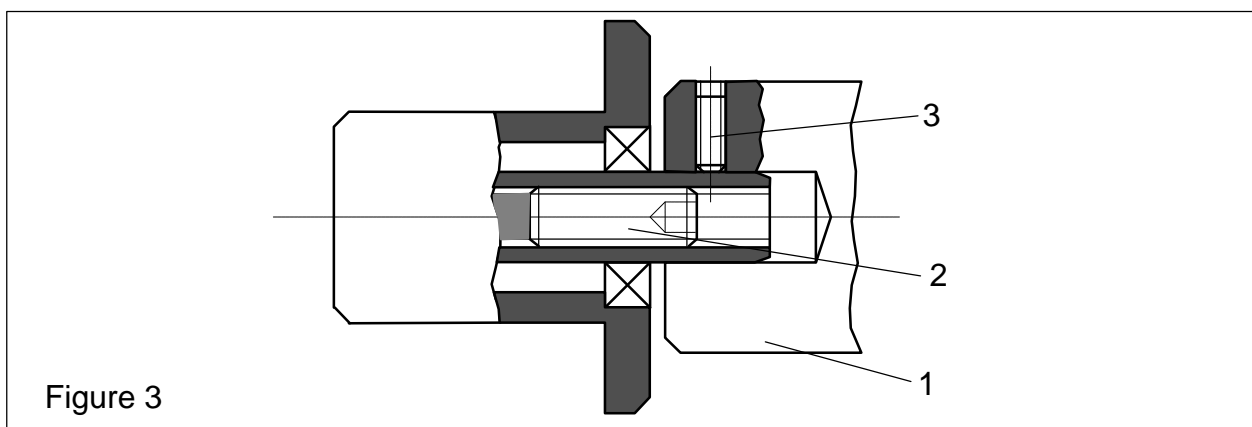

Figure 3

### 3.4 Readjustment of paper brake

The braking force is factory-set to an optimum value. Should it, however, be unadjusted, readjust it with the M3-bolt (2) in the web-end controlbox of the traction unit, from the outside.

- Screw in bolt = higher braking force
- Unscrew bolt = lower braking force

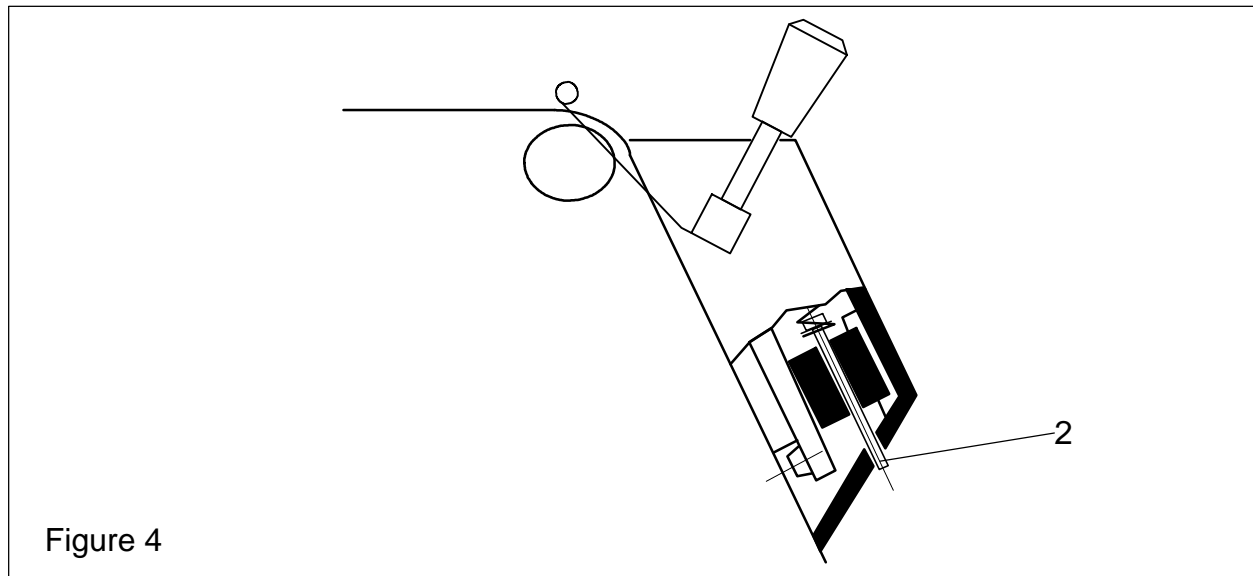

Figure 4

### 3.5 Longitudinal adjustment on the module rail

Unscrew 4 bolts with special tool (wrench for socket head cap screws 5 mm) one half turn (adapter only 2 bolts).

Move device, observing scale on module rail. Then tighten bolts equally.

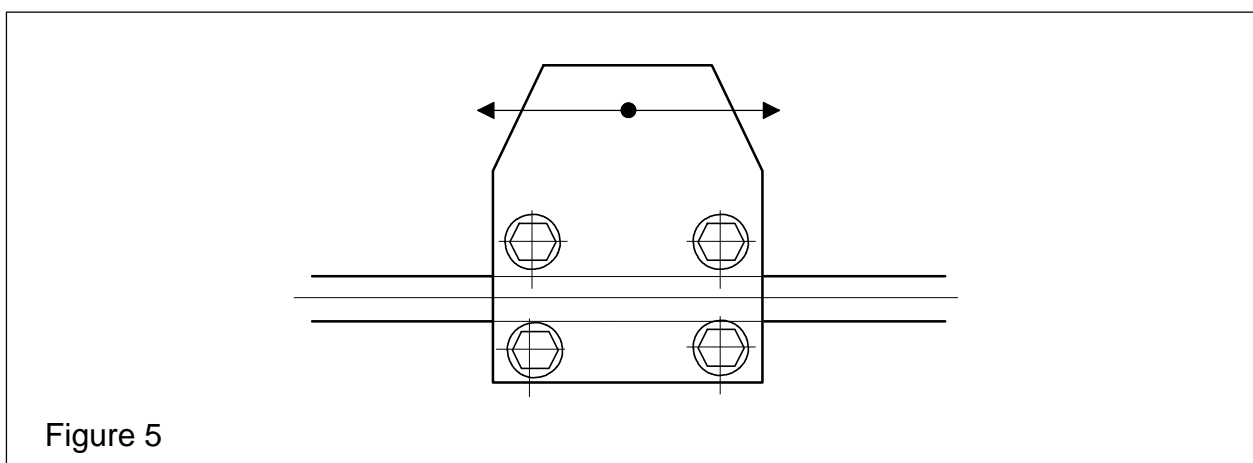

Figure 5

## 3.6 Flap adapter

### 3.6.1 Inclination adjustment of flap adapter

The inclination of the flap adapter can be changed against the module rail: Unscrew nut **(1)** with two turns (refer to figure 7), with special hexagonal spanner (included as accessory). Push adapter in the direction indicated by the arrow **(2)**, turn to desired setting at ring **(3)**. Retighten nut **(1)**.

The pressure force of the flap adapter without magnet or of the magnetic flap adapter is variable: push in button **(4)** in the direction indicated by the arrow, twist for appropriate spring tension and adjust until it meets the next stop.

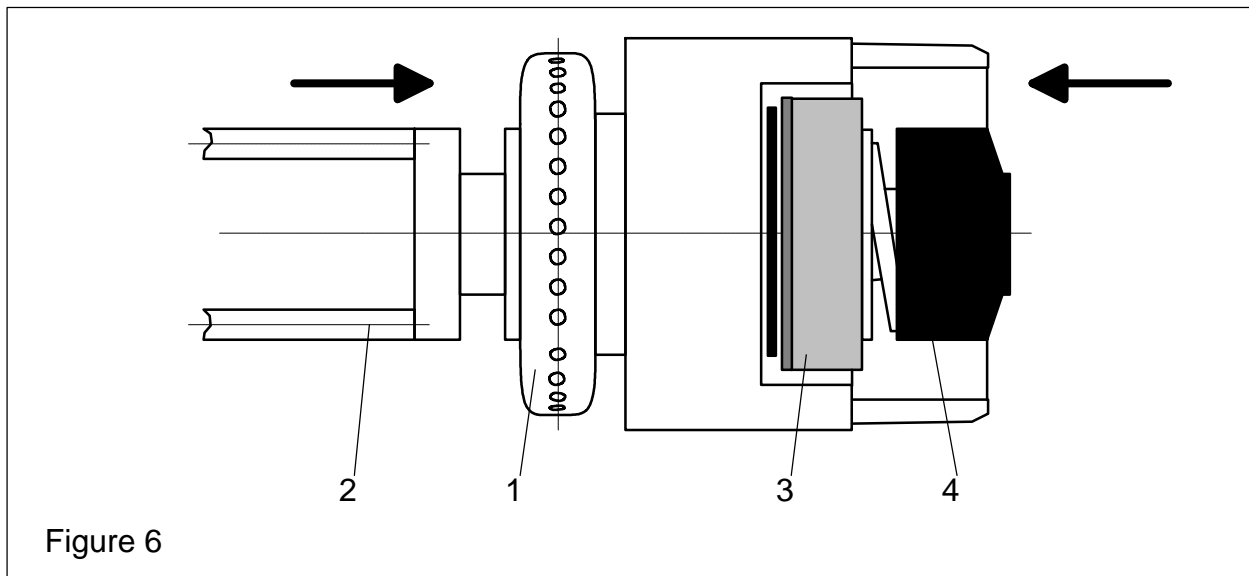

### 3.6.2 Adjustment of the pressure roller of the flap adapter

The pressure roller of the adapter can be adjusted depending on the labels and goods:

- Horizontal adjustment with the knurled nut **(5)**
- Vertical adjustment with the hexagonal nut **(6)**

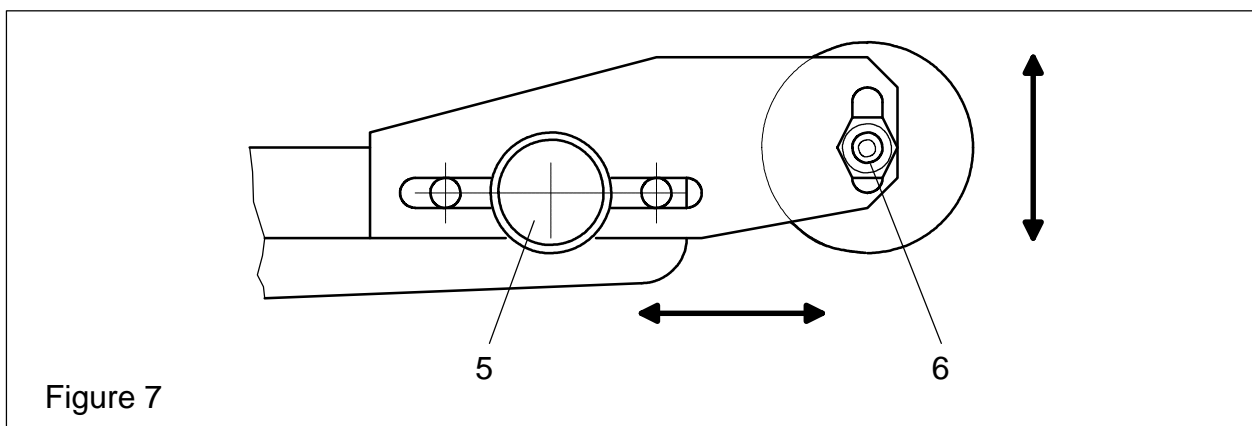

### 3.7 Optical label scanner

The adjustment of the label scanner must be done on the monitor. This is described on page 16 in the operating instructions of the monitor C8600.

For the manual adjust the paperweb must be pulled, so that the gap between the labels is under the marking 1 of the scanner.

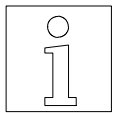
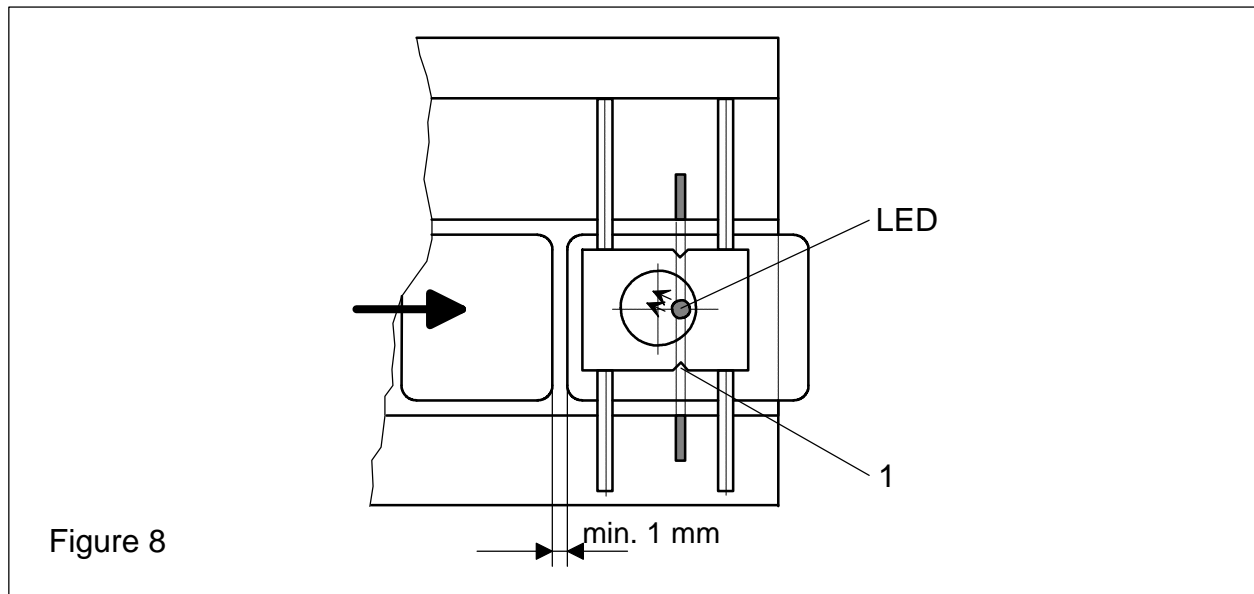

**Remark:**

**If the setting of the optical label scanner is faulty, the gap will not be detected. This gives an error message to the monitor display.**

**For clear or transparent labels, please use the mechanical label scanner.**

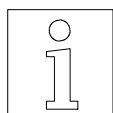

**For clear or transparent labels, please use the mechanical label scanner.**

### 3.8 Adjustment of the mechanical label scanner

The mechanical label scanner (not used on magnetic flap adapter) is an alternative to the optical label scanner and is mainly used for transparent labels.

Adjustment:

- Place the label under the scanning head, the LED on the scanner support must be turned on. If this is not the case, unscrew the nut on the scanning head and turn it counterclockwise until the LED turns on.
- Turn the scanning head clockwise until the LED turns off.
- Turn the scanner one quarter turn forward and retight the nut.
- Place the gap between the labels under the scanning head, the LED-display must be turned on.

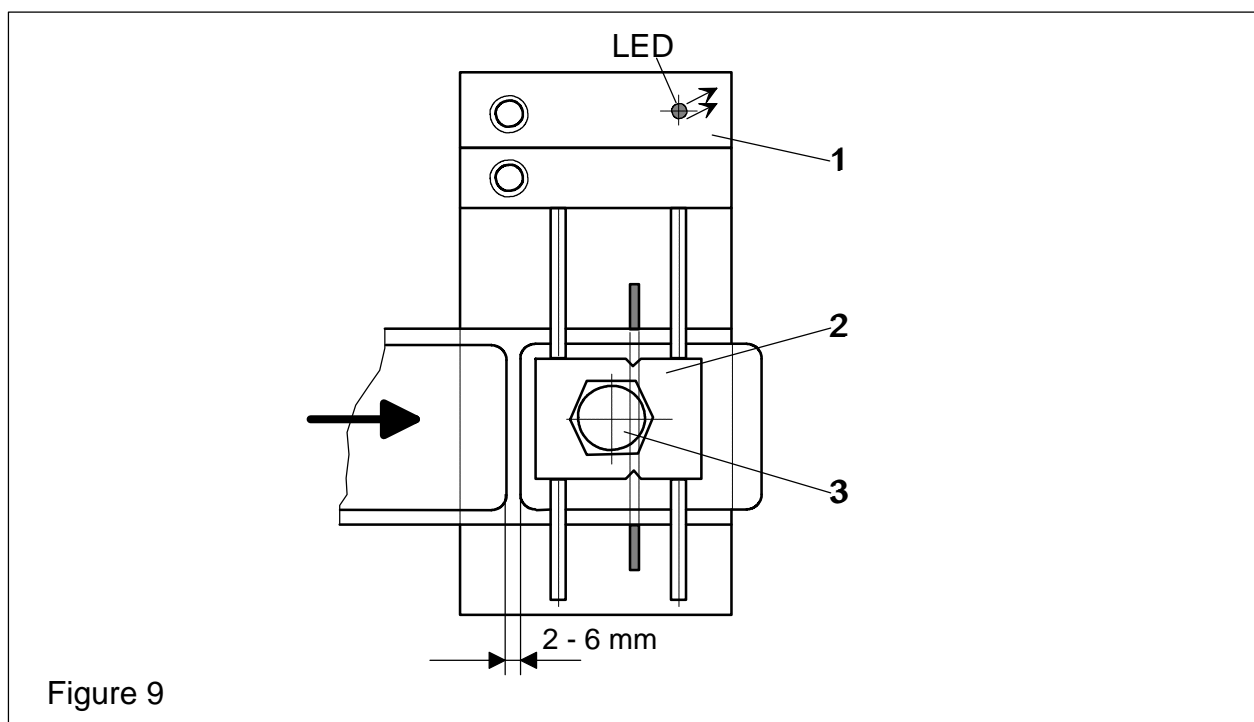
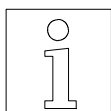

Figure 9

1. Scanner support
2. Scanning head
3. Nut



**Note:**  
**No adjustment is necessary on the monitor unit!**

## 4 Nonstop labeling

When using two Collamat® 8600 it is possible to label goods with no down time. For this purpose the two monitors are connected together by an electrical link. The placement of the two Collamat® to each other is shown in figure 10:

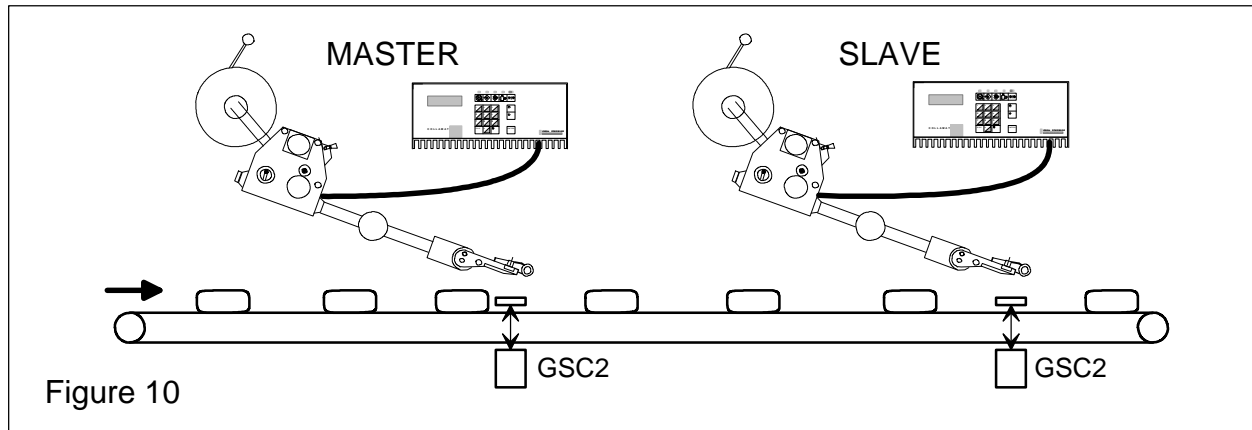

### Setting up of the Nonstopmode

When the wiring of the nonstopmode is made, the installation must be set up as follows:

- Stop the conveyor or the goods transportation
- Remove all the goods in between of the two GSC2
- Set both monitors to STOP
- Set up the two labelers
- Choose Nonstopmode MASTER on the master
- Choose Nonstopmode SLAVE on the slave
- Set monitor master to RUN
- Set monitor slave to RUN
- Start the conveyor or the goods transportation

The goods are now labeled in the nonstopmode. If an error occurs which causes a stop of a Collamat® the following proceeding is necessary:

- Service the erroneous condition on the stopped Collamat® Confirm the errormessage on the monitor with the ENTER key

If an error occurs which stops both Collamat®, first the error condition must be serviced. Then all the goods in between the two GSC2 sensors must be removed. The nonstop-counter must be cleared on the monitor of the master.

For the supervision and setting up the nonstopmode, in the free selectable display, the counter of the goods in between the two GSC2 scanners, can be displayed.

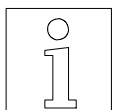

**The distance of the GSC2 to the peeling edge must be in this case the same on both labelers.**

## 5 Servicing

The Collamat® 8600 is free of servicing. But please note, that the equipment has to be cleaned from time to time according to use. Especially the paper dust, adhesive residues as well as colour remainders of the printing group.

It is very important to clean the paper brake and the label scanner. After each cleaning, all paper guiding elements like rolls (exceptional the traction unit), shafts and dispensing edge, have to be sprayed with a silicon spray.

## 6 Glossary

### 6.1 Short cuts

<b>ESD</b>	<b>E</b> lectro <b>S</b> tatic <b>D</b> ischarge
<b>RMI</b>	<b>R</b> adio <b>M</b> agnetic <b>I</b> nterference
<b>GND</b>	<b>G</b> rou <b>N</b> D
<b>LCD</b>	<b>L</b> iquid <b>C</b> ristal <b>D</b> isplay
<b>LED</b>	<b>L</b> ight <b>E</b> mitting <b>D</b> iode
<b>nc</b>	<b>n</b> ot <b>c</b> on <b>n</b> ected
<b>RS232</b>	<b>S</b> tandard serial data exchange protocol

### 6.2 Signals

<b>ERROR</b>	<b>E</b> rrorsignal caused by any error of the Collamat®
<b>FEED</b>	<b>S</b> ignal indicating the labeling process
<b>GND</b>	<b>G</b> rou <b>N</b> D
<b>GSC</b>	<b>G</b> oods <b>S</b> Canner
<b>HOT</b>	<b>H</b> OTstamp connection, for the connection of a hotstamp
<b>IFEED</b>	<b>I</b> solated <b>F</b> EED signal
<b>LLO</b>	<b>L</b> abel <b>L</b> ow signal indicating the end of the label stock
<b>LSC</b>	<b>L</b> abel <b>S</b> Canner
<b>nc</b>	<b>n</b> ot <b>c</b> on <b>n</b> ected
<b>NOK</b>	<b>N</b> ot <b>O</b> K, something not OK
<b>NSTPI</b>	<b>N</b> on <b>S</b> To <b>P</b> <b>I</b> N-put
<b>NSTPO</b>	<b>N</b> on <b>S</b> To <b>P</b> <b>O</b> U <b>T</b> -put
<b>READY</b>	<b>R</b> EADY signal from peripheral units
<b>RWF</b>	<b>R</b> e <b>W</b> inder <b>F</b> ull
<b>TCY</b>	<b>T</b> ransparen <b>C</b> Y, <b>C</b> ontrol current for the label scanner IR-diodes
<b>TUNIT</b>	<b>T</b> raction <b>U</b> NIT, signal that supervises the traction unit

## 6.3 Terms

**Stopping accuracy:** Accuracy of the paper transportation

**Unwinder:** Device that carries the full paperweb rolls and unwinds it

**Adapter:** Part of the labeler. Here the label is peeled of the paperweb by pulling it over a sharp edge

**Rewinder:** Device that takes the empty paperweb from the traction unit and rewinds it

**CE-Mark:** Certification for the European market, means: **C**onformité **E**uropéenne

**Collamat®:** Brand name for a labeler built by Collamat Stralfors AG

**C8600:** Labeler type C8600

**GSC: Goods S**Canner

**Flap adapter:** Adapter which moves to the product during the labeling

**LSC: L**abel **S**Canner

**LC-Display, LCD:** Liquid crystal display

**Machine status:** Working mode of the Collamat®. E.g.: Stop, OK, ERROR

**Monitor:** Controlbox containing all electronic boards of the Collamat®

**Position:** Sticking position of a label on the good

**Predispensing:** Predispensing of a label on the peeling plate

**Motorstep:** Traveling way of the label for one motorstep

**Dispensing speed:** The speed of the goods to which the labels are stucked

**Speed:** See also dispensing speed

**Startfrequency:** Highest possible frequency for a stepper motor to start moving without loss of steps

**Traction unit:** Part of the dispenser in which the paperweb is pulled

## 7 Technical data

### Dispenser general data (standard values)

System	Units	C8610	C8620
Version		right/left	
Dispensing speed	m/min	0.5-50	0.5-50
Min. label width	mm	10	
Max. width of the paperweb	mm	95	160
Min. label length	mm	10	10
Min. label length @ max. dispensing speed	mm	20	
Stop accuracy	mm	@ 40 m/min $\pm$ 0.5	
Minimal gap for optical scanner	mm	2	
Minimal gap for mechanical scanner	mm	2	
Max. diameter of paperroll	mm	250/350	
Max. weight of paperroll	kg	10	
Noise figure max.	dB(A)	< 70	

### Traction unit

System	Collamat® 8600	
Driver	3-Phase stepper motor 500 steps	
Motor voltage	120V	
Max. phase current	5.0 A	
Type of protection	IP40	
Ambient temperature	+5-40 °C	
Ambient humidity	15-90%, non condensing	
Noise figure max.	< 70 dB(A) @ 1 m distance	
System	C8610	C8620
Weight	12 kg	14 kg

### Midi-unwinder

Diameter of the roll core	42 mm
Max. outside diameter of roll	350 mm
Max. weight of roll	10 kg
Spring dancer with automatic brake	

## Label scanner

Optical label scanner
Mechanical label scanner

## Flap adapter

System	C8610	C8620
Max. width of paperweb	95 mm	160 mm
Weight	1.9 kg	2.2 kg
Version	right/left	
Adapter angle	±90°, with adjustable snap-in locking	
Recuperating spring force	adjustable	
Additional press time of adapter	adjustable	
Max. cadence on max. turning angle	20'000 cycles/h	
Max. turning angle	15°	
Ambient temperature	+5-40°C	
Ambient humidity	15-90% non condensing	

## Monitor

System	Collamat® 8600
Mains voltage	110/120V, 220/230/240V, ±10%
Power consumption	310 VA
Main fuse	120V : 8AT, 230V : 4AT
Display	LCD, 4 lines, 20 characters each
Dimensions (LWH in mm)	375 * 305 * 155 mm
Ambient temperature	+5-40°C
Max. ambient humidity	15-90% non condensing
Type of protection	IP40
Weight	approx. 15.5 kg

**The information in this handbook reflects the state of the publication date.**  
**We reserve the right to make design modifications.**

## 8 Connection diagram

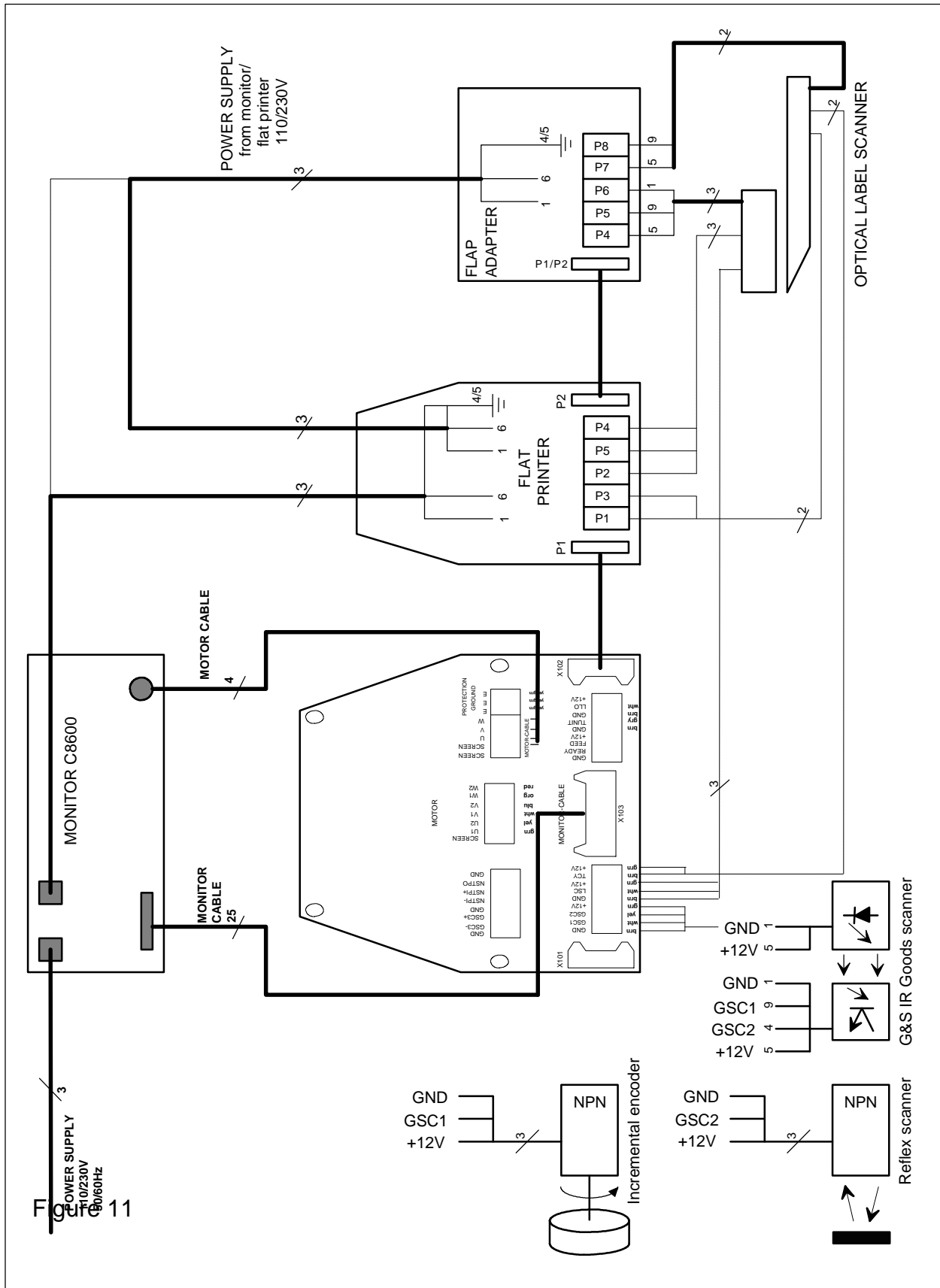

## 9 Trouble shooting checklist

<b>Machine-Type:</b>		Ser.No. Monitor:	Ser.No. Labeler:
Ser.No Control panel:	Software-Version:	Ser.No. Motordriver:	Ser.No. Interfaceboard:
<b>Environment</b>	Mains voltage:	Frequency Hz:	Temperature °C:
	Humidity %:	Interference level (Burst):	Interference level ESD (Static):
<b>Labels</b>	Width:	Length:	Gap:
	Thickness:	Transparency:	Material:
<b>Paperweb</b>	Width:	Thickness:	Transparency:
<b>Goods</b>	Kind:	Material:	Shape:
	Length:	Width:	Height:
	Speed m/min:	Length in sense of transport:	Distance between goods:
<b>Labeler</b>	Speed m/min:	Pieces / min.:	Measuring:
<b>Settings</b>	Predispensing:	Position mm:	Suppression:
	TCY value:	Label length:	Suppression:
<b>Special:</b>			
<b>Machine-environment</b>	Conveyor:	Feeder:	Taker:
	Other machines around:		
<b>Peripheral units</b>	1	2	3
<b>Screening</b>	Mains cables:	Sensor cables:	
<b>ESD-Phenomena</b>	Description:		
<b>Description of the malfunctions:</b>	Accumulation	frequent:	
		repeated: .....	seconds
		spontaneous:	
Date / ev. date and time of the last disturbances:			
<b>Comments:</b>			
Disturbance registered by Name:			
Date:			

Please make a copy of this list before using it.